



CASTER CITY

8635 Bright Angel Way
Las Vegas, NV 89149
800-501-3808

REVISIONS:

DATE	#	COMMENT	BY

PART NO: LV0050V2

DIMENSIONS AND TOLERANCE ARE IN INCHES UNLESS SPECIFIED:
X ±1 .X ±0.5 .XX ±0.25 FRACTION ±1/16 ANGLES ±1°

SPECIFICATIONS:

1. MATERIAL: DIE CAST ALUMINUM FRAME WITH STEEL SWIVEL
2. LEVELING FOOTPAD
3. ADJUSTABLE RANGE: +.47
4. HIGH STRENGTH NON MARKING NYLON WHEEL
5. STATIC LOAD CAPACITY: 110 LBS

DATE	12/22/2015
SCALE	
PAGE	1 OF 1
DRAWN BY	E.T.
APPROVED BY	S.C.

EXTENDED FOOT PAD

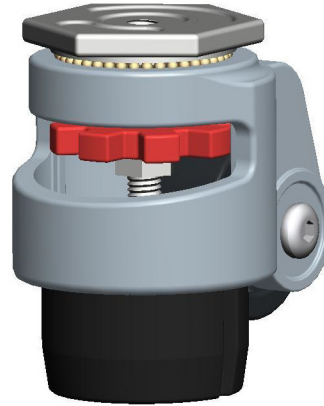
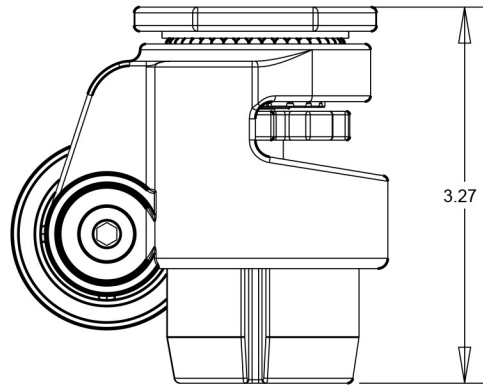

RETRACTED FOOT PAD

